

Crystal Autoclave

Specifications for a Crystal 300 E & DS

Design Features

- 300 litres
- MP25 Controller
- Square chamber
- Fixed Seal
- Robust space saving design
- Integral drip tray
- Grade 316 stainless steel chamber
- Anti door bolt over tight mechanism
- Complete versatility for almost any application

Optional Accessories

- Loading Baskets
- Waste Discard System
- Fan Assisted High Speed Cooling
- Condense Collector, which eliminates a drain requirement.
- Air removal HEPA filter (for CAT3 environments)
- Data Printers & Chart Recorders
- Vacuum & Drying options
- Anti Lime scale system
- Loading Trolleys & Carriages
- Air Ballasting



Capacities and dimensions (approx)

Model	Crystal 300
Autoclave Weight	500kg
Export Case Size	990w x 1970h x 1610d
Overall Dimensions	830w x 1800h x 1450d
Chamber Dimensions	510 x 510 x 1030d
Chamber Capacity	300 Litres
Water Consumption (in chamber / typical per cycle)	750ml
Water Consumption (Steam generator / typical per cycle)	16 litres
1L Media Bottles	36
2L Media Bottles	20
500ml Media Bottles	55
NHS Discard Boxes	H250xW320xL320 (6)
Trolley	H1045xW580xL1290

Crystal 300

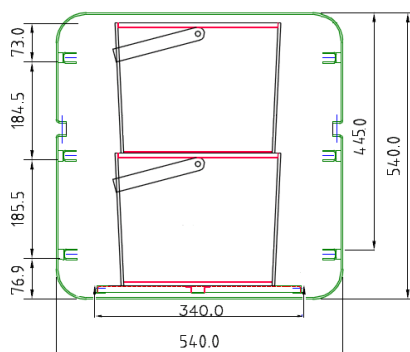
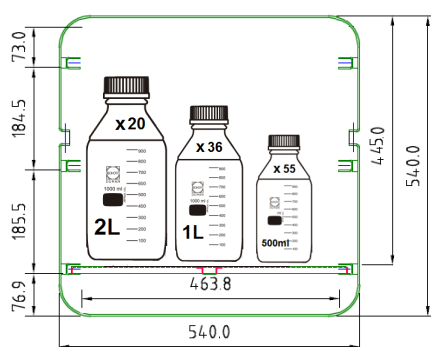

Not to scale





Safe Design Operating Limits	
Model	Crystal 300
Max working temperature	138°C
Min working temperature	7°C
Max ambient temperature	28°C
Min ambient temperature	11°C
Max hydraulic pressure	4.14 Bar
Max working pressure	2.62 Bar
Max working vacuum	Minus 1 Bar

Human Scale

Typical Installation

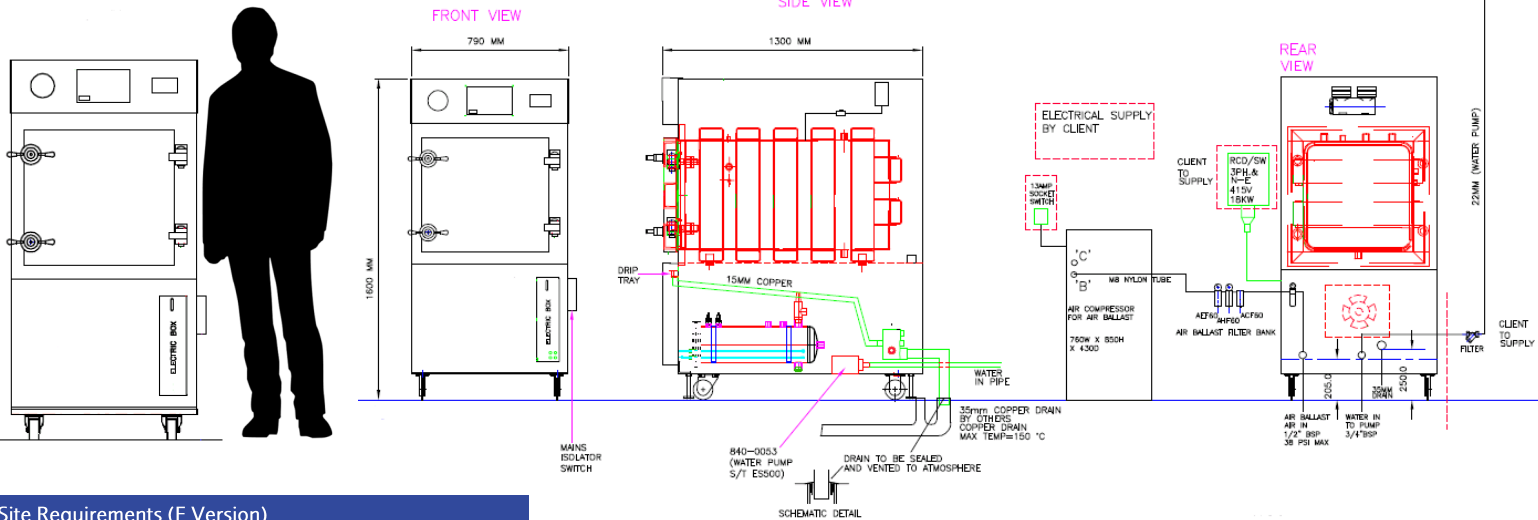

Site Requirements (E Version)	
Electrical site requirement: 40 Amp Switched RCD required	
Model	Crystal 300E
Drain Requirements	150°C 35mmØ Copper
Voltage	380/415v
Phase Requirement	3ph/N 50/60 Hz
Power Consumption	18kw
Fuse Rating	40 amp

Option Requirements

- Air Supply at 38 psi, 7 cfm required for Air Ballasting option
- Post Cycle Drying will require AC701C vacuum option.
- Drain requirement of 150°C, 35Ømm copper pipe at floor level.

General Requirements

- Sodium Chloride must not exceed a level greater than 500 ppm.
- Use regular mains water only. DO NOT USE distilled or RO water
- DS Version requires a mains steam supply of 38psi 9kw 35lbs/hour

Site Requirements (DS Version)	
Electrical site requirement: Switched RCD required	
Model	Crystal 300DS
Drain Requirements	150°C 35mmØ Copper
Mains Steam Supply	35 lb p/h @ 2.67 Bar
Voltage	230v
Phase Requirement	1ph/N 50/60 Hz
Power Consumption	1kw
Fuse Rating	6amp

Complying Standards

- PED Cat 3 Module B+D Notified Body: British Engineering No. 0040
- Harmonised Standards applied: EMC BS EN 61326
- Community directives applied : Pressure Equipment Directive – PED 2014/68/EU (formerly PED 97/23/EC)
- Designed in accordance with PD5500 (formerly BS5500) & BS2646
- Chamber and Door constructed of stainless steel BS-EN 10028-7:316
- ISO 9001: 2008
- CE Marked

Information is subject to change to suit different options added. This information is correct as of 10th January 2017, E & OE